



The worldwide **Conveyors** of automated garment sorting, storage & retrieval

Stor-U-Veyor / Consec-U-Veyor

Die-Cast Aluminum Yokes

10 Slot Cast Aluminum Frames

Bi-Directional Hand Switch

Custom Configurable

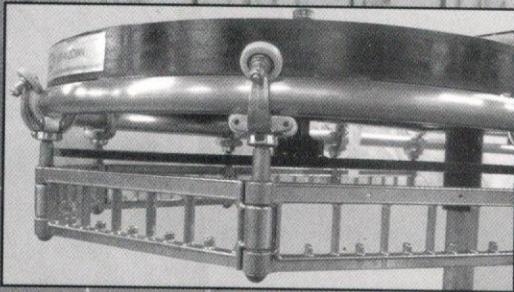

STOR-U-VEYOR

White's most popular garment storage conveyor design, the Stor-U-Veyor, provides storage with SLOTS. This system offers convenient identification and retrieval of garments in any numbering system.

The Stor-U-Veyor can operate bi-directionally with the provided manual hand or foot control. An optional keyboard allows automatic operation. In this case, the shortest retrieval route for an item is calculated by an on-board microprocessor for fast service.

FEATURES

- Direct drive motor with soft start feature.
- Custom designed for the maximum increase in your storage capacity.
- Each configuration can be expanded or altered as your needs change.
- Bi-directional hand switch – standard.
- Automatic keyboard control – optional. Microprocessor control selects shortest route to item location.
- Die-cast aluminum frames with rust proof finish, 10 slot, 12" pitch.
- Screw type take up for chain slack adjustment (optional).



CONSEC-U-VEYOR

The Consec-U-Veyor is a conveyor with NO SLOTS - a continuous revolving rail allows bundles to be consolidated by simply pushing the orders together. The Consec-U-Veyor is ideal for filling in alphabetical or consecutive order ticketing systems. An automated "slick rail" system saves space and labor.

FEATURES

- Direct drive motor with soft start feature.
- Bi-directional hand switch - standard.
- Stamped steel, plated load bar for smooth movement of hangers.

Garment Conveyors

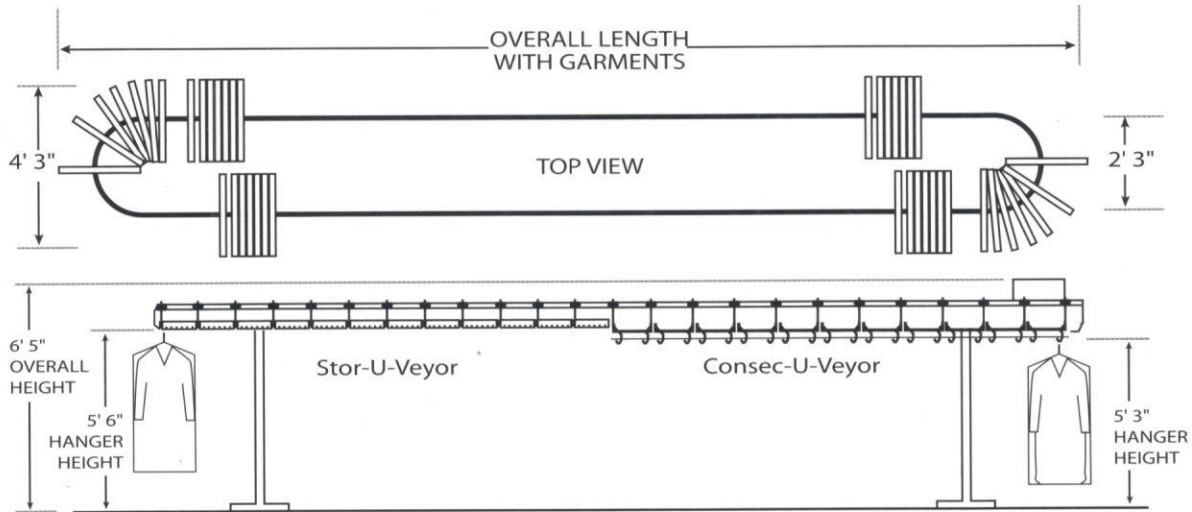

TYPICAL MODULAR SECTION SHAPES

White Conveyors are available in a wide variety of special shapes. You can "design your own conveyor" to fit most any length or shape by using our standard "modular" sections. Here are some typical shapes.

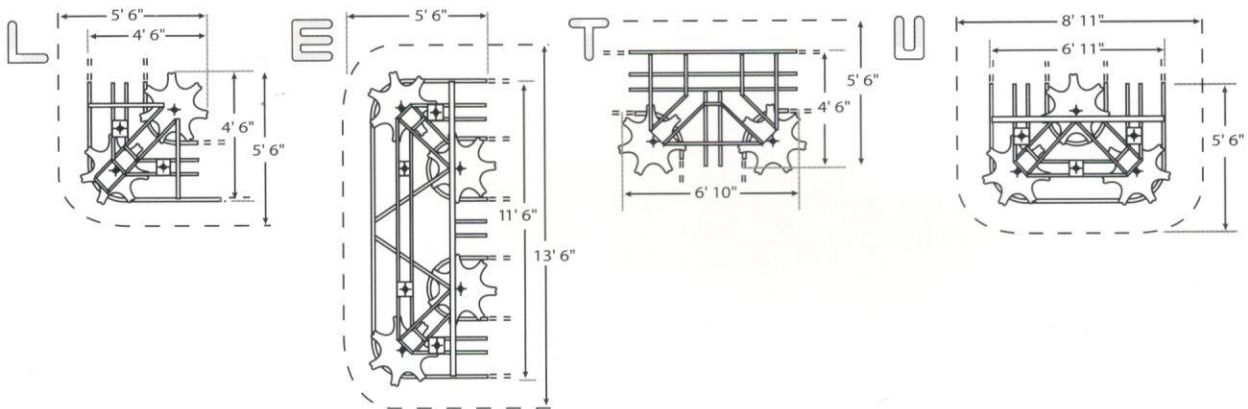

STOR-U-VEYOR

Model No.	No. of Slots	Length of Hanging Capacity	Overall Length w/ Garments
W220	220	22'-0"	12'-0"
W260	260	26'-0"	14'-0"
W300	300	30'-0"	16'-0"
W340	340	34'-0"	18'-0"
W380	380	38'-0"	20'-0"
W400	400	40'-0"	21'-0"
W420	420	42'-0"	22'-0"
W460	460	46'-0"	24'-0"
W500	500	50'-0"	26'-0"
W540	540	54'-0"	28'-0"
W580	580	58'-0"	30'-0"
W600	600	60'-0"	31'-0"
W620	620	62'-0"	32'-0"
W660	660	66'-0"	34'-0"
W700	700	70'-0"	36'-0"
W740	740	74'-0"	38'-0"
W780	780	78'-0"	40'-0"
W800	800	80'-0"	41'-0"
W820	820	82'-0"	42'-0"
W860	860	86'-0"	44'-0"
W900	900	90'-0"	46'-0"
W940	940	94'-0"	48'-0"
W980	980	98'-0"	50'-0"
W1000	1000	100'-0"	51'-0"

CONSEC-U-VEYOR

Model No.	Length of Hanging Capacity	Overall Length w/ Garments
C22	22'0"	12'0"
C26	26'0"	14'0"
C30	30'0"	16'0"
C34	34'0"	18'0"
C38	38'0"	20'0"
C40	40'0"	21'0"
C42	42'0"	22'0"
C46	46'0"	24'0"
C50	50'0"	26'0"
C54	54'0"	28'0"
C58	58'0"	30'0"
C60	60'0"	31'0"
C62	62'0"	32'0"
C66	66'0"	34'0"
C70	70'0"	36'0"
C74	74'0"	38'0"
C78	78'0"	40'0"
C80	80'0"	41'0"
C82	82'0"	42'0"
C86	86'0"	44'0"
C90	90'0"	46'0"
C94	94'0"	48'0"
C98	98'0"	50'0"
C100	100'0"	51'0"